



# PECAHAN



**A** Tandakan (✓) pada benda yang dipotong kepada bahagian-bahagian yang sama besar. Tandakan (x) sebaliknya.

3.1(i) B2D4E1

1

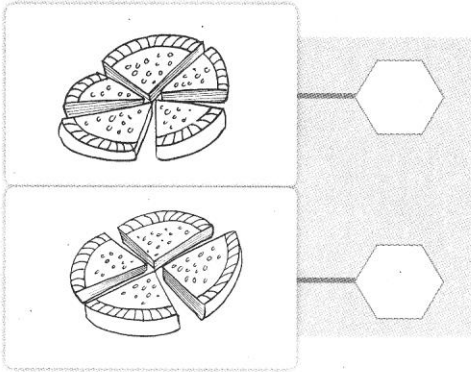

2

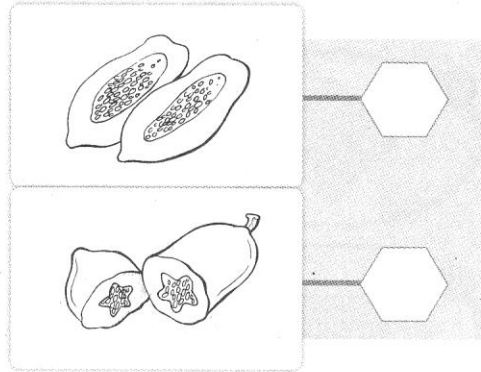

3

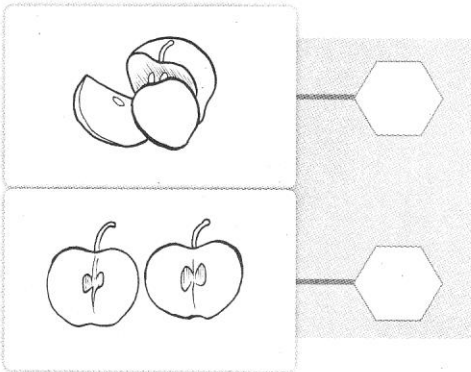

4

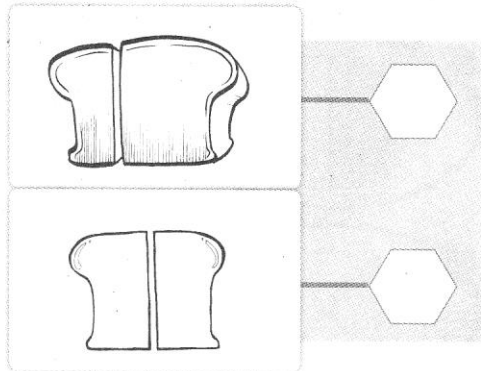

5

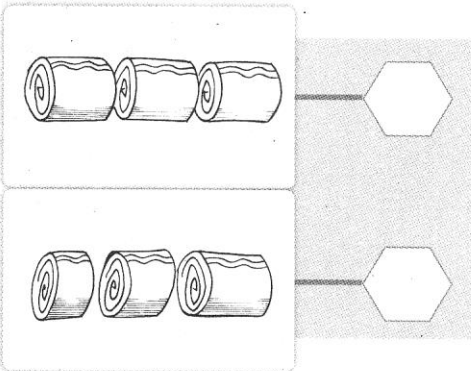

6

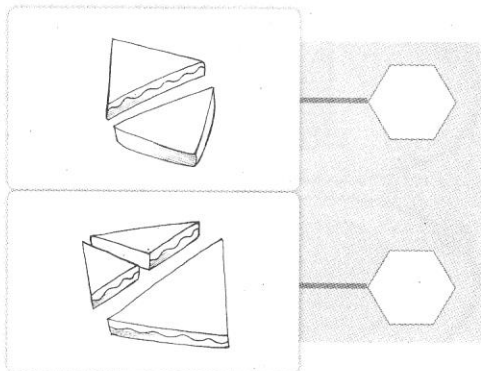

Tema	Band	Standard Kandungan	Standard Pembelajaran	Deskriptor	Evidens	Standard Prestasi
Pecahan	2	3.1 Mengenal pasti konsep satu perdua dan satu perempat.	3.1(i)	B2D4	E1	B2D4E1

**PENILAIAN**

Menguasai

Tidak Menguasai

Tandatangan guru: \_\_\_\_\_